

Make Storage Purposeful with Lockers

LOCKER
GUIDE

Locker Design

Spaces are constantly changing, whether that be the design, layout, or perhaps even the purpose. Lockers don't have to be one-size-fits-all. Our lockers are designed for versatility and flexibility, which means you can get the perfect solution for every square inch of your space.

It's time to make storage purposeful.

What does this mean? Lockers are more than just a place to store things—they can transform a space's aesthetic and help reinforce flexibility, as well as enable a user-friendly experience. Let's take a look at our extensive locker capabilities.



MODERN
OFFICE SYSTEMS, LLC



We tailor the locker design to your unique space and needs. Each project is custom designed. Take a look at our capabilities.

Custom Lockers

DOORS & HINGES

Stainless steel soft-close, adjustable hinges mounted on either side of opening for a perfectly aligned door. A full overlay door, standard 3/4" laminate with edgebanding for a clean look.

INSIDE A LOCKER

Choose from hooks, charging stations, hanging bars, and more to customize the inside of your locker. See page 11 for more.



ONE BANK, DIFFERENT SIZED OPENINGS

Customize the locker bank to meet your needs with different sized tiers within the same locker bank.

1 TIER 2 TIER 3 TIER 4 TIER 5 TIER 6 TIER 2 TIER

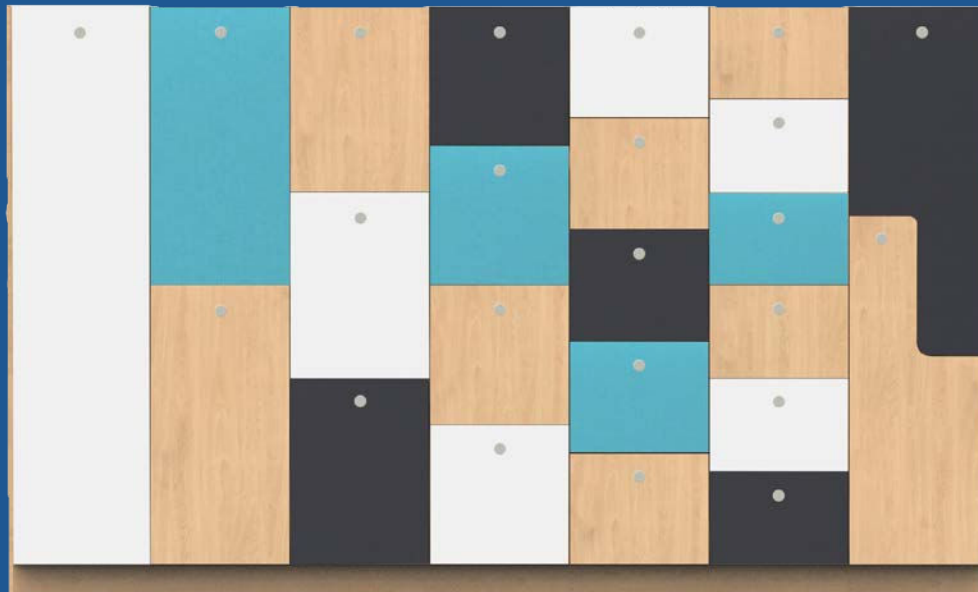

LAMINATE COLORS

We have a variety of laminate colors to choose from to complete your look. See page 12 for more.

BASE HEIGHT

A 4" base is standard, but adjust to your needs and eliminate the bottom row so no one is left with a bottom locker.



SLOPED TOPS

Sloped tops help prevent clutter from storing items on top of the lockers, while also reducing the build-up of dust.



MAIL SLOTS

Make mail and parcel delivery easy with the addition of mail slots. It's quick and efficient for the delivery person, while being secure and convenient for the users.

Custom Locker DESIGN

Our typical locker heights are used as a starting point when designing lockers. Here are just a few of our standard heights to get started. The 40" height lockers are ideal for a collaborative island that can be configured to allow for seating or an extended tabletop. The 54" height lockers are great for wall partitions in an open-concept space. The 72" lockers can be built into the wall and incorporate bench seating for a versatile design.

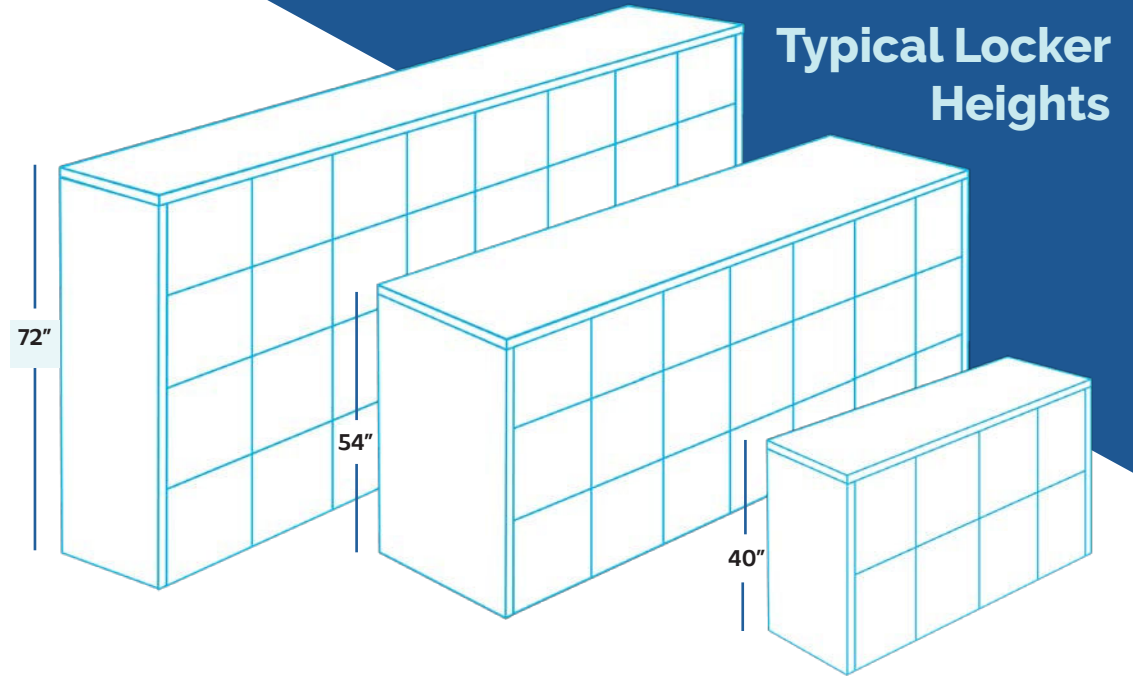

Locker Configuration Guidelines

Standard Widths

12"
15"
18"

*Custom 12" - 24"

Standard Depths

15"
18"
20"

*Custom 12" - 24"

Standard Heights

36" 68"
40" 72"
54" 80"

*Custom 36" - 90"

Locker Design

These loose guidelines are used as a starting point in the design process. We provide a curated locker solution that meets your unique needs. Take a look at some of the locker applications to get a better understanding of the versatility and flexibility of lockers.

Lock Types

Learn more about our locking options on pages 13-14.

Smart Networked



Smart Wireless



Battery



Mechanical



When space is limited, why not make use of that extra wall space? Lockers can be incorporated right into the wall, making them a smart and stylish way to maximize your space. The unique design of lockers allows them to blend right into the environment or make them stand out with a custom design.

Built-In Locker Walls

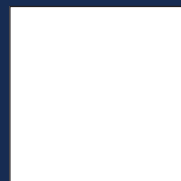
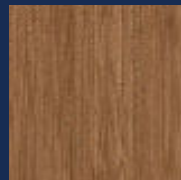

Built-In Locker Wall DESIGN

At Modern, we have seen it all when it comes to lockers. We work with you to design the ideal solution — custom is our standard. The modular nature of our locker solution helps meet your specific needs.

When built into the wall, lockers can blend into the space, or with unique designs, can be a statement piece. Lockers with media displays are great for meetings or presentations and we can help you design a display that will create a media wall. If you need to change shoes during the day or just rest your feet after lunch, incorporating a bench is the way to go.

Locker Configuration Guidelines

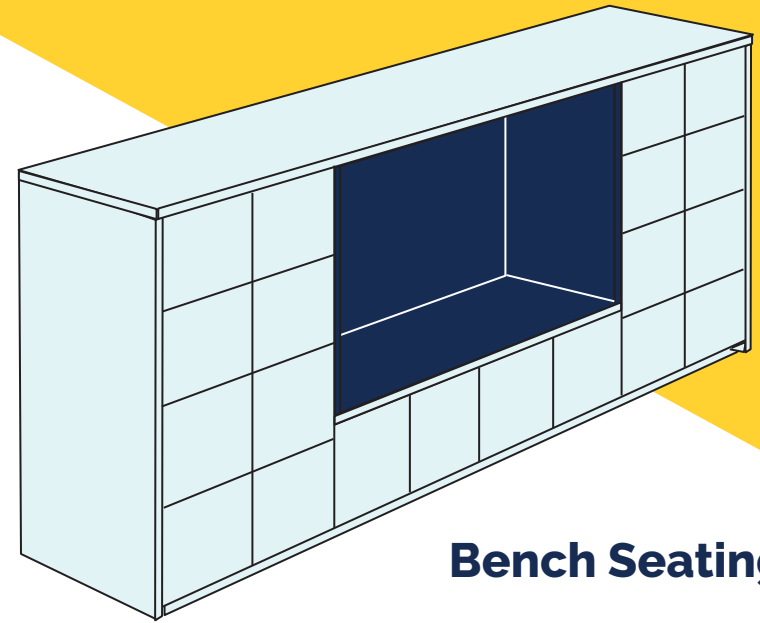
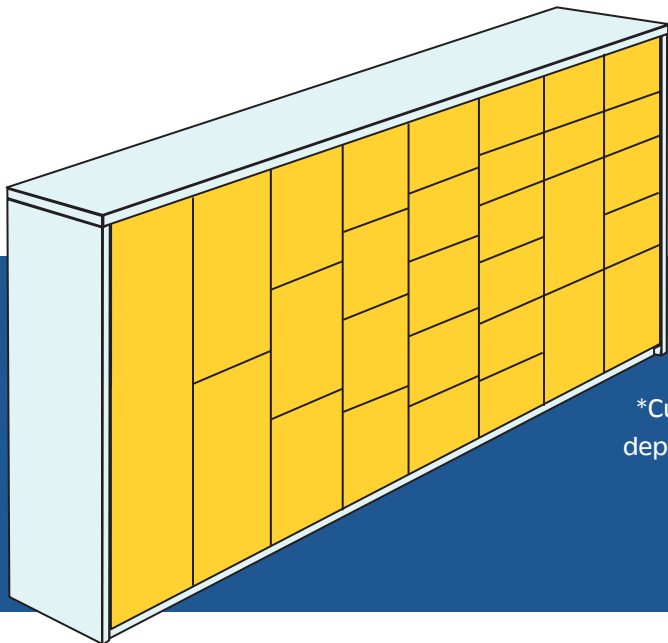

Bench Seating

Built-In Locker Wall Heights & Depths

LENGTHS: With a minimum of one column to however many columns needed to fit in the space. Filler panels can be added to make it a perfect fit. See below for locker column standard and custom widths.

HEIGHTS: Design your locker wall to be a typical modular wall configuration or a city-scape design with a varying heights of locker columns. Typical wall heights are 68" or 72" plus a base.

Locker Standard Sizes

*Custom sizes available on inch-increments. Custom widths and depths range from 12" to 24" wide columns. Custom heights from 36" to 90" high. Does not include height of base.

Width	Depth	Height
12"	15"	54"
15"	18"	68"
18"	20"	72"
		80"

It can be difficult to delineate space when you're working in a large, open area. When you introduce locker wall partitions into the space, they give you the ability to create a sense of privacy and delineation without actually closing off your workspace. Plus, they're sleek and modern—perfect for any space that needs functional or design updates. The customization is practically limitless—open cubbies to allow light to pass through, phone booths for individual work calls, or the addition of tack boards to the back, perfect for collaborative meetings.

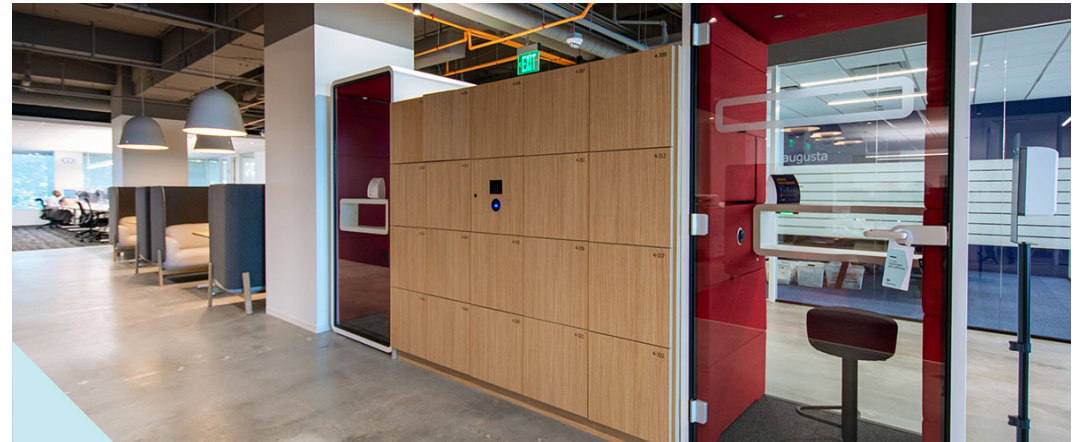

Wall Partition Lockers

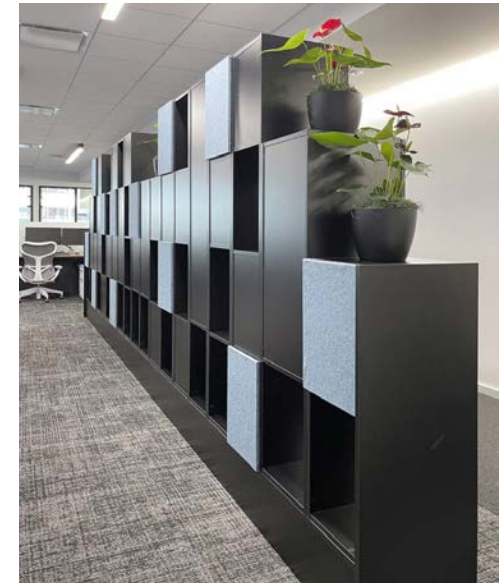

Wall Partition Lockers

DESIGN

Our modular walls and lockers are designed to work together in any environment. With the option to combine lockers, cabinets, and shelving, they can be placed flat against the wall to provide needed storage space or can be used to dissect a room into two smaller areas for team collaboration or another type of activity-based working.

Our lockers and cabinets can be configured to create partitions in an open space while providing the necessary storage your teams need for their personal belongings. When you need every inch of your space to perform double-duty, our modular walls might be just the ticket.

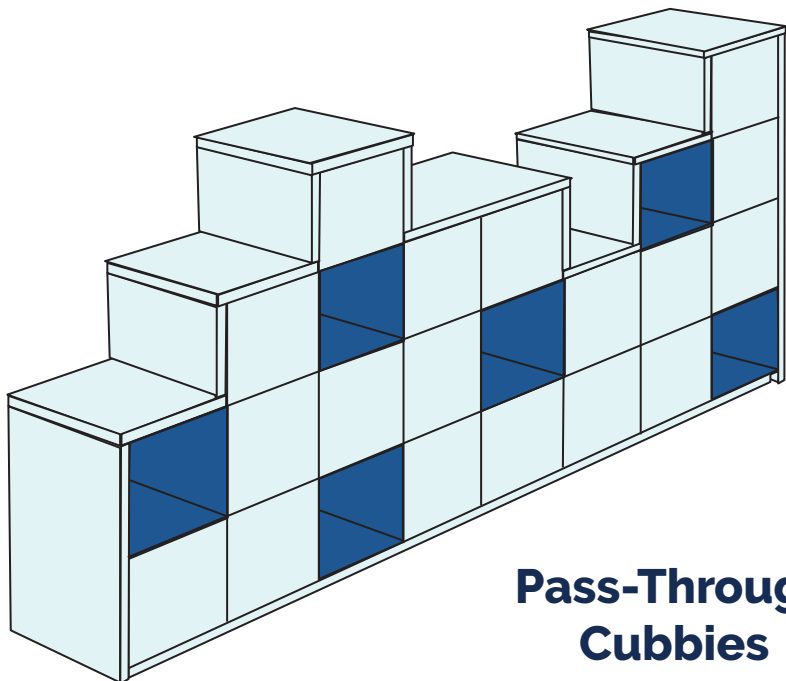

**Pass-Through
Cubbies**

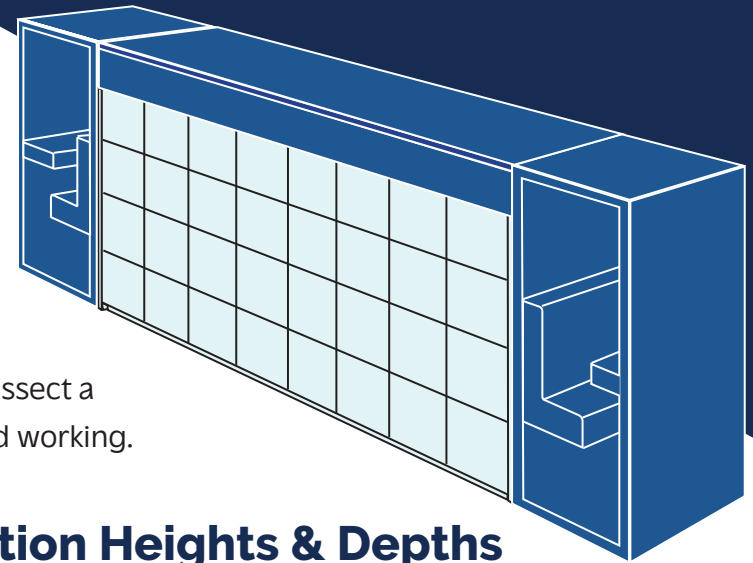

Wall Partition Heights & Depths

LENGTHS: A minimum of one column to as many columns as needed to fit in the space. Filler panels can be added to make it a perfect fit. See Locker Sizes for locker column standard and custom widths.

HEIGHTS: Design your wall partition to be a typical modular wall configuration or a city-scape design with a varying heights of locker columns. Typical wall heights are 68" or 72" plus a base.

DEPTHS: Wall Partitions can be single or double-faced. Single-sided allows for locker storage on one side and a blank canvas on the other. A place for collaboration with whiteboard laminate, tack board, media display and more. Or, put your locker columns back-to-back for storage on both sides.

Locker Standard Sizes

*Custom sizes available on inch-increments. Custom widths and depths range from 12" to 24" wide columns. Custom heights from 36" to 90" high. Does not include height of base.

Width	Depth	Height
12"	15"	54"
15"	18"	68"
18"	20"	72"
		80"

In an office, end-caps are perfect for sectioning off desks and providing personal storage right at their desks. Add recycle and trash receptacles to conceal trash bins. Include mail-slots with name tags to easily and efficiently distribute mail or other documents. With the addition of storage drawers on the bottom row, no user will be assigned a bottom row of lockers. Place the RFID reader on the top or on the side of the locker bank to optimize the user experience and allow for easy access.

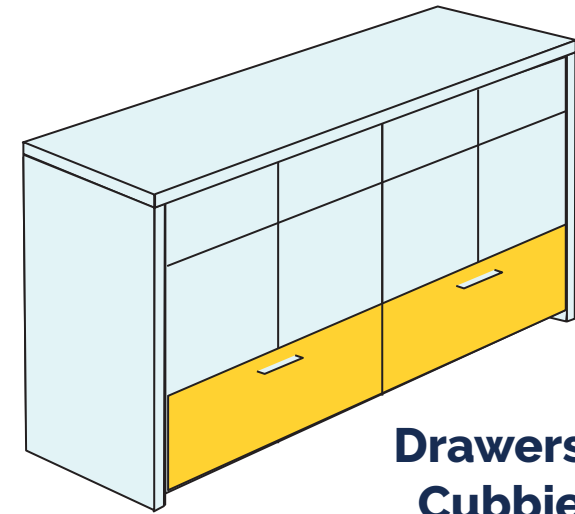

Drawers & Cubbies

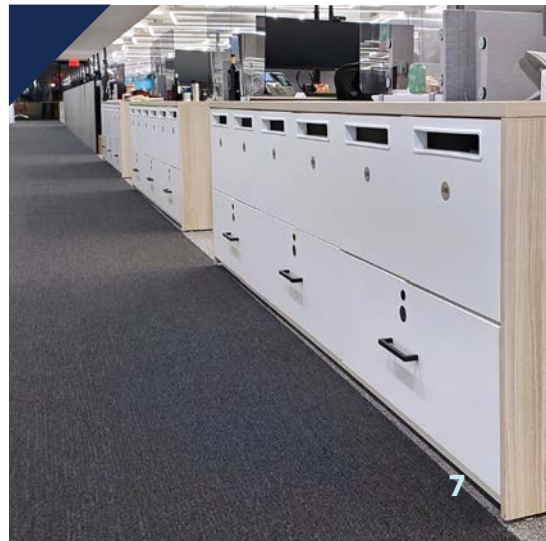

End-Cap Lockers **DESIGN**

End-Cap Heights & Depths

Design with any of the base heights or modular and storage solution bases for industry standard heights:

Bar Height — 42"

Counter Height — 34"

Work Surface Height — 29.5"

Locker Standard Sizes

Width	Depth	Height
12"	15"	36"
15"	18"	40"
18"	20"	

*Custom sizes available on inch-increments. Custom widths and depths range from 12" to 24" wide columns. Custom heights from 28" to 42" high. Does not include height of base.

Exchange of Goods Locker **DESIGN**

Exchange of goods lockers are gaining traction in recent years. From workplace office mail and parcel delivery to university library materials, lockers are streamlining the exchange of goods. When it comes to IT equipment, users can securely drop-off and pick-up items without tracking down the IT Department. Design locker banks to be flexible with your needs, mixing and matching locker door sizes within the same bank.

Locker banks can also be used in libraries or across campus, helping students seamlessly pick up and drop off materials at their convenience. Students can quickly return library materials without waiting in line at the library desk while librarians can have an easier time managing all the materials coming and going from the library.

*For locker sizing, refer to Built-In Locker Wall Sizing Guide

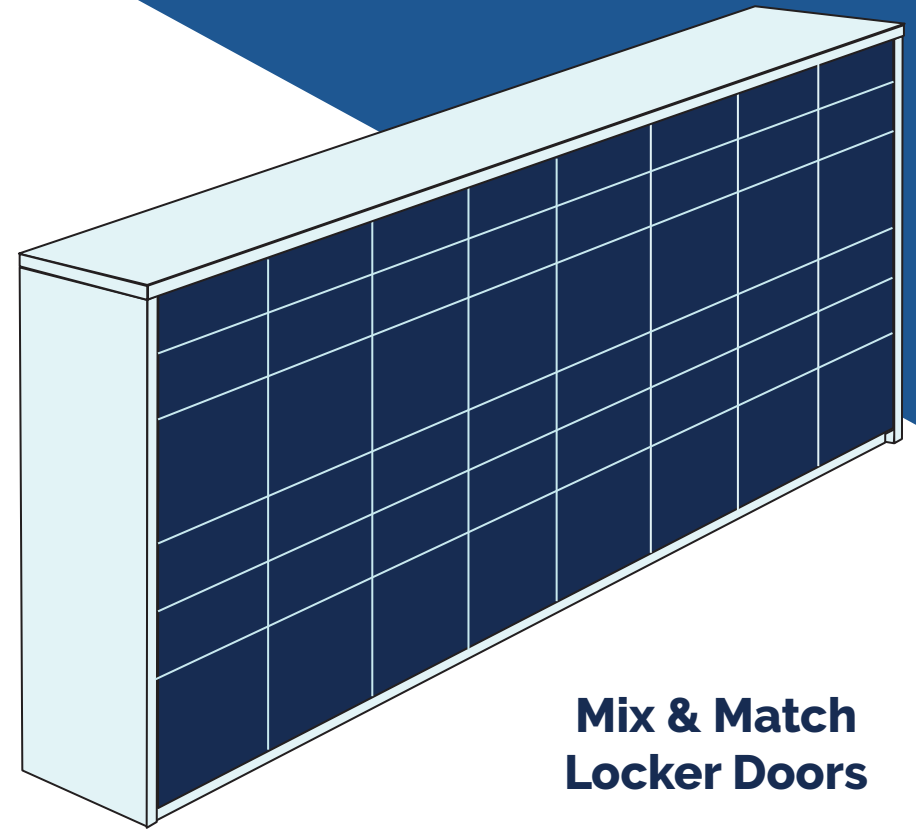

**Mix & Match
Locker Doors**



Design to match your company's already-existing design aesthetic with a range of colors, textures, and finishes. Add solid-surface for a high-end finished counter-top like surface or a painted-glass or writable laminate for a whiteboard surface for brainstorming. Incorporate space for legroom for seating or built-in recycle and trash receptacles to keep your space clean.

Collaborative Islands

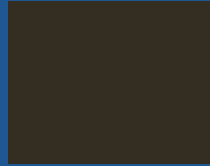

Collaborative Island **DESIGN**

People-first design is crucial to any functional and practical space. And that means having places to work, talk, and collaborate spontaneously. That's where it helps to have collaborative islands that can serve as a storage location and a space for quick stand-ups. Available as stationary units — or add even more flexibility by making them mobile.

When you're trying to make the most of your space, a collaborative island doesn't need to be fixed — especially when space is at a premium. Each piece we produce is custom-designed with high-pressure laminate and is durable — meaning you can relocate these pieces in confidence.

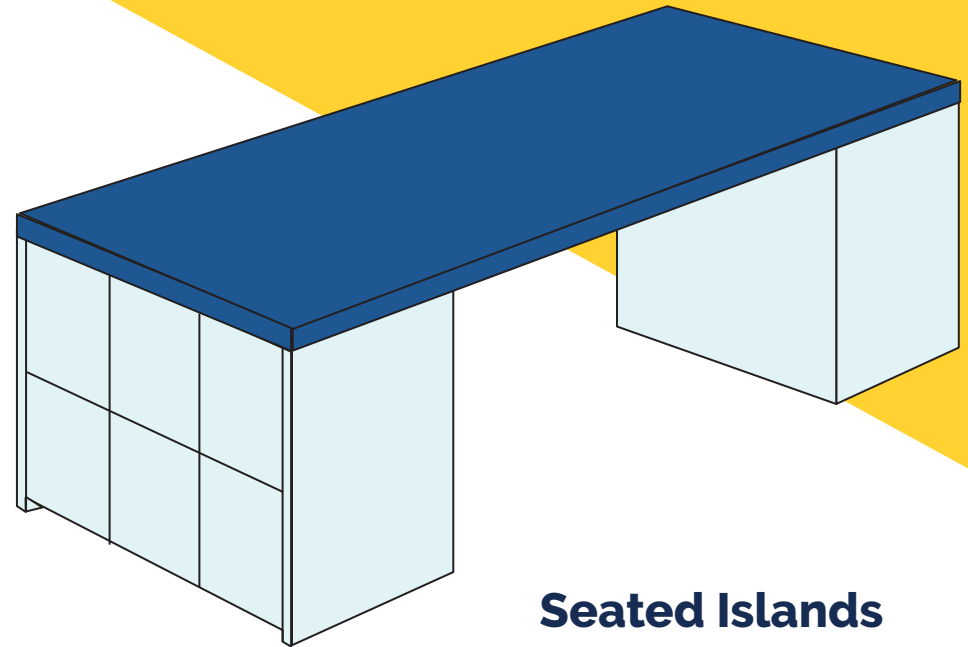
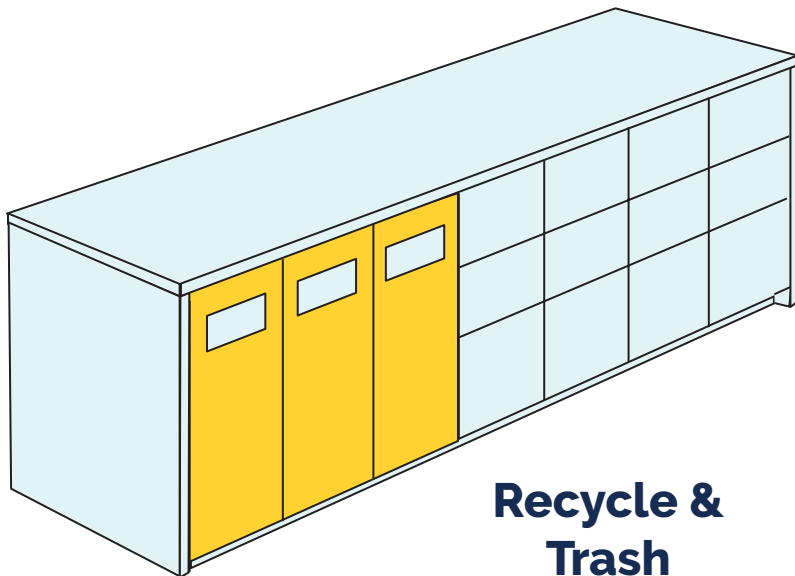

Collaborative Island Heights & Depths

Design with any of the base heights or modular and storage solution bases for industry standard heights:

Bar Height — 42"

Counter Height — 34"

Work Surface Height — 29.5"

Locker Standard Sizes

Width	Depth	Height
12"	15"	36"
15"	18"	40"
18"	20"	

*Custom sizes available on inch-increments. Custom widths and depths range from 12" to 24" wide columns. Custom heights from 28" to 42" high. Does not include height of base.

Inside a Locker

DESIGN

When it comes to user experience, it's the little details that count. A well-designed space is one that caters to the known and unknown needs of the people using it. The same goes for lockers.

A coat hook is more than just a hook—it's the first step of coming into the office and settling in for the day. Every day, each person has a small, invisible routine when placing their belongings into their locker: they hang up their jacket, put their personal bags away, grab a drink from the fridge and sit down at their desk.

Make their experience more seamless and intuitive with thoughtful interior design inside your lockers.

STORAGE CADDY

Perfect for pens, phones or any other small handheld that you need.

WALL HOOKS

Double-winged hooks for hanging bags and purses.

HANGER ROD

Hooks to hang your work clothes while you head to the gym.

USB OUTLET

Fully equipped with USB powerpoints to ensure your phone never dies at work again.

DOUBLE-WINGED HOOK

Double-winged hooks are perfect for hats and scarves in the winter.

COLLAPSIBLE SHELF

a full shelf when you need it and a full-length opening when you need to hang coats.

NET STORAGE POUCH

Just like on airplanes, a net is perfect for those small and mid-sized electronics.

BOTTOM DRAWER STORAGE

A place to store your shoes or bulky items that you don't want near other belongings.

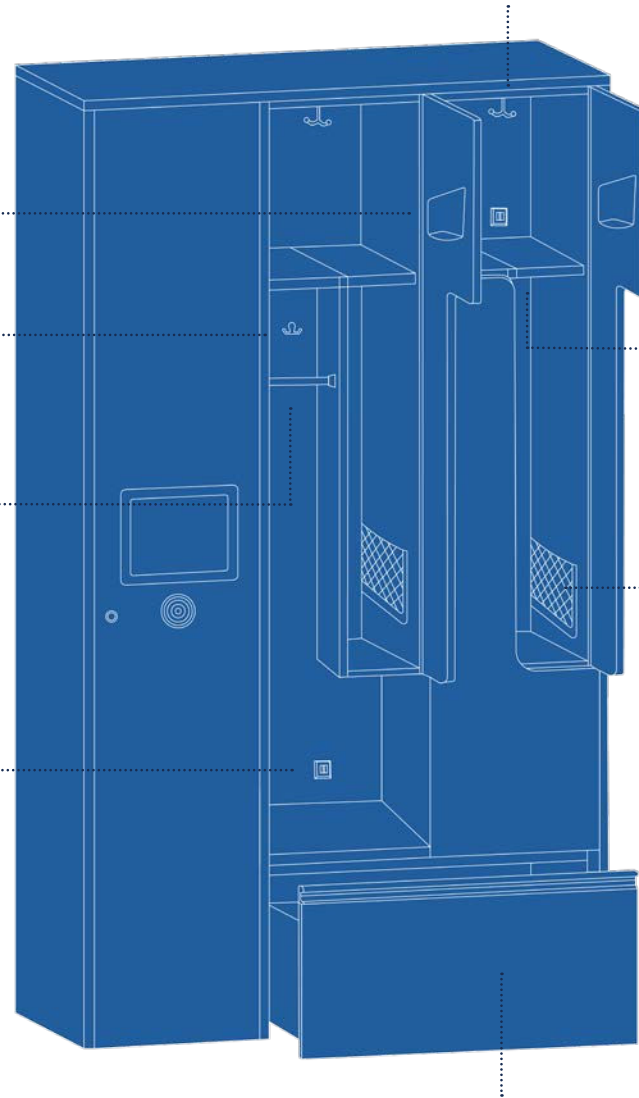

Custom Locker **DESIGN**

Materials

Choose from laminate colors that align with common neutrals that fit in almost any environment or bold colors to make a statement. Take it one step further and create a locker bank with textured doors that stand out while blending into your environment. Phenolic material for your outdoor lockers or fitness centers and spas for the harshest of environments. Or even steel lockers designed with clean lines to showcase any color of durable powder-coat paint.

Custom Graphics

Laminate doors are a great way to take on a more elevated look to match the aesthetic of your company brand or culture. Laminate gives you the unique ability to show off custom graphics that can be vinyl wrapped or embedded in laminate.



Lock Technology

When it comes to locks, you have a lot of options. Whether you're looking for a standard no-fuss lock to keep belongings safe, or a more tech-driven lock system that integrates with other aspects of your building, we've got an option to fit your application and needs.

SMART LOCKS

Wired Smart Locks

Locking systems can provide the most customized and tailored user experience. With a networked locking system, administrators can design the system to access lockers via smartphones, smartwatches, RFID badges or IDs, or even biometrics. These smart locks are designed to provide administrators with locker usage insight and full control to customize the lockers to a streamlined user experience.

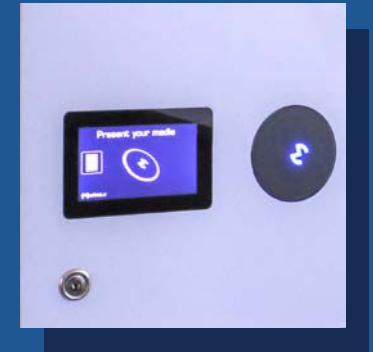

Wireless Smart Locks

Our smart lock solution is meant to be as flexible as possible, so we offer varying levels of 'smart lockers' that can function similarly to traditional wired smart locks. Our wireless smart lock offering gives you a streamlined user experience by using your smartphone or an RFID badge.

ALTERNATIVE LOCK TYPES

4-Digit PIN Code Locks

If you're looking for a lock that's not only secure but also easy to use, a digital keypad lock might be the perfect fit. These locks have an easy-to-understand user interface: the user simply types in a 4-digit PIN code. Even if you're new to lockers, it won't take long for you to feel comfortable with this type of lock.

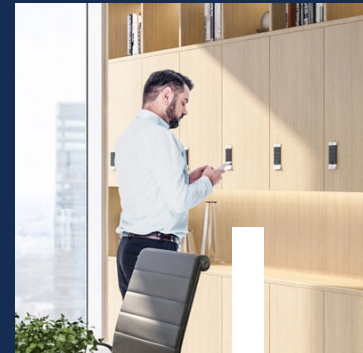

Mechanical Combo Lock

No more batteries, no more recharging. Just a simple lock that's easy to use and even easier to maintain. A mechanical combination lock with a 4-digit combination is the perfect choice for your application when you're looking for something that will be reliable, yet require little to no maintenance.

45 West 36th Street
New York, NY 10018
877.507.2757
modernofficesystems.com